

- 1.2      - 200      30      100%

25

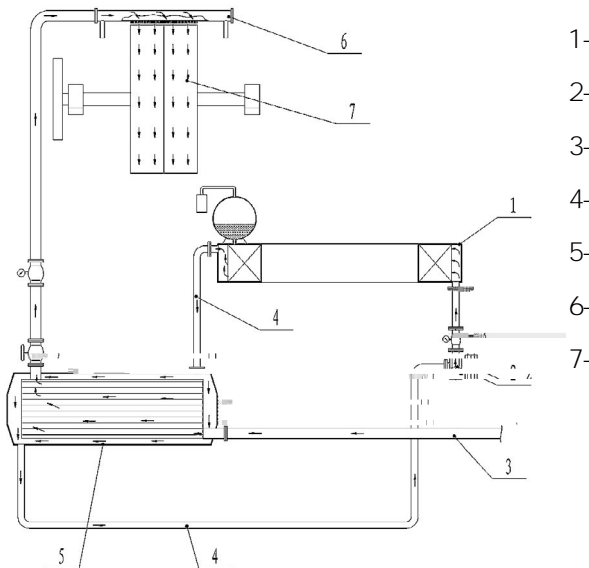

: ZL201110233277. 5      PCT      CN2011/082524  
 : ZL201210028744. 5      [2012] 156  
 : ZL201220332872. 4      [2012] 333  
 : ZL201220041902. 6  
 : ZL201310335484. 0      JK      [2012] 1050  
 : ZL20162025241. 6



- 1-
- 2-
- 3-
- 4-
- 5-
- 6-
- 7-

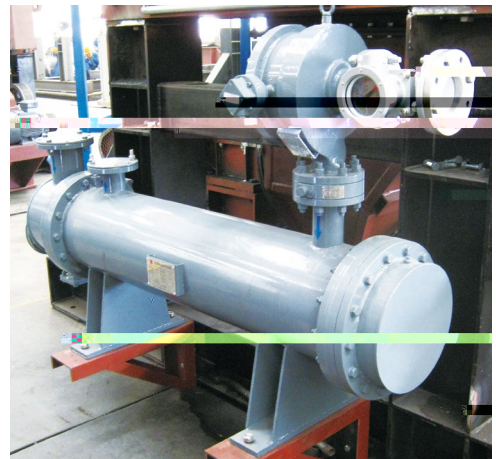

	LHGC-500F(Z)	LHGC-750F(Z)	LHGC-1000F(Z)	LHGC-1250F(Z)	LHGC-1500F(Z)	LHGC-1750F(Z)	LHGC-2000F(Z)	LHGC-2250F(Z)	LHGC-2500F(Z)	LHGC-2750F(Z)	LHGC-3000F(Z)	LHGC-3500F(Z)	LHGC-4000F(Z)	LHGC-4500F(Z)	LHGC-5000F(Z)	LHGC-6000F(Z)
(T)	1.1/1.4(0.6)															
(T)	2.4(1.2)															
kW	20/3	25/8	20.6/38.5/10	19/48.6/12.38/48/15.5	43/56/23	49/68/35	51/72/32	65/76/41	69/94(42)	72/106/50	93/122/52	102/128/58	110/135/65	128/140/75	150/175/98	
t/h	0.03 0.125	0.1 0.5	4 7	10 30	20 30	30 50	50 80	80 120	100 150	100 200	150 250	250 400	350 500	450 700	600 800	800 1000
m³/h	0.25 0.5	1 2	12.5 20	20 50	50 100	75 150	100 200	160 300	200 400	200 500	350 650	550 1000	750 1400	1100 1700	1400 2000	2000 3000
A	124/40	50/35	41/100/70	70/125/65	120/125/110	120/140/125	140/185/130	146/215/120	165/175/120	175/190/100	185/210/150	205/220/180	263/285/205	270/290/220	272/300/330	370/400/300
%	10 35															
mm	- 1.0		- 1.2													
r/min	2 4( )															
mm	500	750	1000	1250	1500	1750	2000	2250	2500	2750	3000	3500	4000	4500	5000	6000
kW	0.18	0.75	1.1	1.5	3	4	5.5	7.5	11	7.5	15(11)	18.5 15	30(18.5)	37(30)	45(37)	55(45)
kW	0.55	1.5	2.2	3	4	4	7.5	7.5	11	15	18.5	30	37	45	45	55
mm	0 30( )															
( / )	0 300( )															
DCV	0 514															
Mpa	0.1 0.2		0.2 0.4													
m³/h	0.65 1.4	1.4 2.5	8 14	20 30	30 50	50 80	80 120	100 150	150 200	200 250	250 350	350 450	450 600	500 700	550 800	650 900
(t)	1.1	1.1/0.5	3.8/2	5/3.5	13/4	15/9	24/20/13	23/25/16	24/25/17	30/33/19	35/36/26	46/45/28	44/46/35	45/48/40	47/50/42	49/50/46
(mm)	2137	2900/2800	3180	3200	3870	4030	4320	4600	5820	6100	6240	7750	8450	8970	9500	9800
			3120	3400	3900	4100	4350	4720	5900	6250	6920	7830	8450	9000	9500	9850
	1602	2300/2100	2590	3100	2700	2840	3860	4380	5940	6250	6260	7750	8300	8730	9400	9500
			2700	3180	3320	3550	3810	4400	4690	5430	5540	5680	5870	6290	7000	7700
	2059	2000/1900	2500	3080	3650	4060	4480	4800	5500	5920	6610	7450	8470	9200	9650	11900
			2380	2700	3200	3500	2900	4100	5175	5670	6280	7140	7990	8900	9300	10500
---	YTS-810	YTS-810 YTS-1210	YTS-810 YTS-1210	YTS-810 YTS-1210	YTS-1415 YTS-2019	YTS-1415 YTS-2019	YTS-2019 YTS-2529	YTS-2019 YTS-2529	YTS-2529	YTS-2529	YTS-2529	YTS-2529	YTS-2529	YTS-2529	YTS-2529	YTS-3040

( )

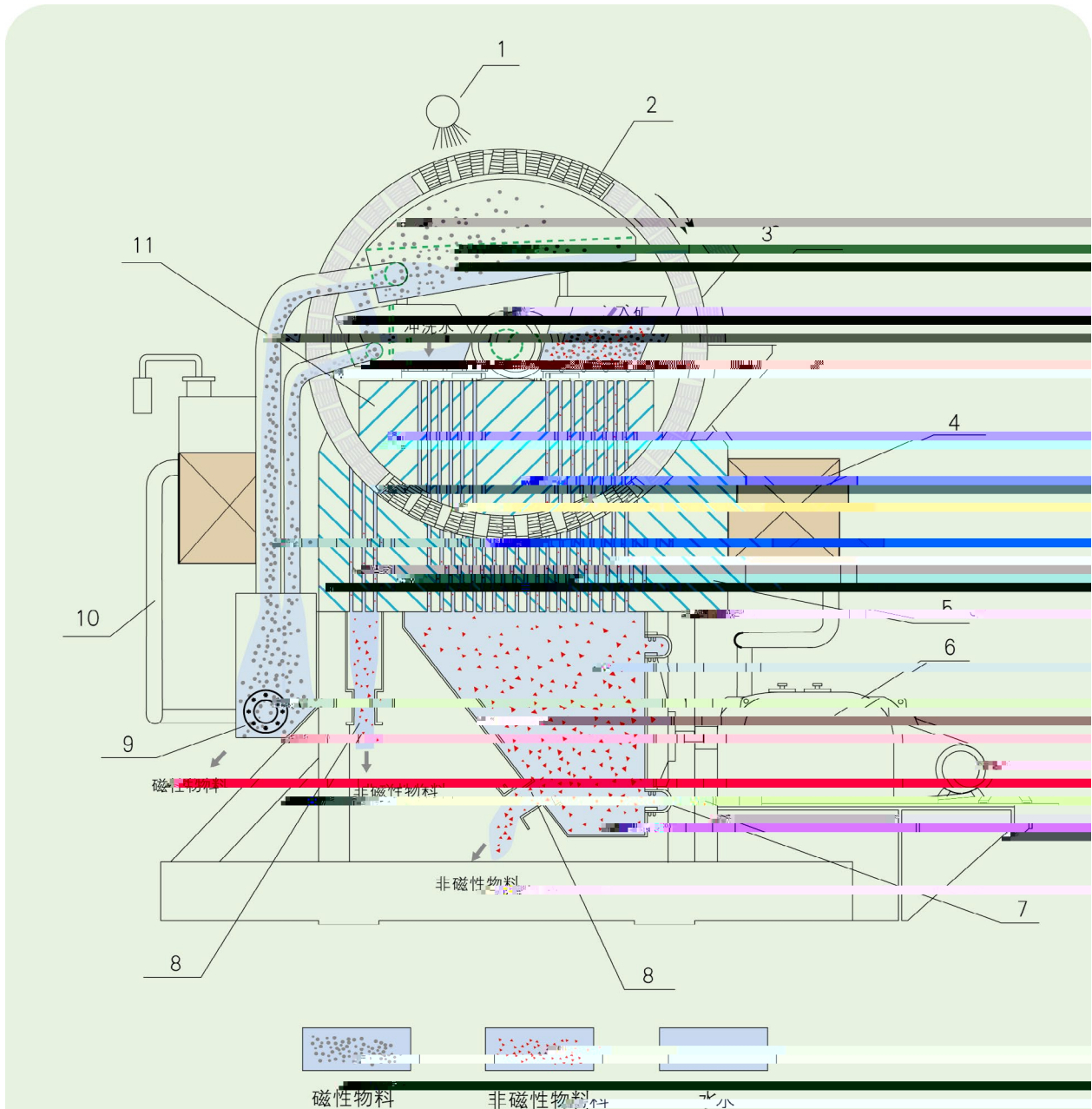

1. 卸矿水    2. 磁介质    3. 转环    4. 励磁线圈    5. 下磁极    6. 排矿管  
 7. 橡胶衬    8. 磁性物料收集斗    9. 非磁性物料收集斗    10. 矿料斗    11. 电动机

磁场对物料吸力的计算:  $F_{磁} = K \cdot X_s \cdot B \cdot \Delta H \cdot V$

( $F_{磁}$ —磁场对物料的吸力;  $K$ —吸力常数;  $X_s$ —磁化率系数;  $B$ —分离磁场的磁感应强度;  $\Delta H$ —分离磁场的磁梯度;  $V$ —物料体积)